



BEVERAGE-AIR

Project: _____	AIA#
Item: _____	
Location: _____	SIS#
Approved: _____	

FB72HC BOTTOM MOUNT: VISTA® SERIES

VISTA® BOTTOM MOUNT REACH-IN FREEZER

MODEL:
FB72HC-5G

FB72HC Glass Door Reach-In Freezer
Hydrocarbon Series



5 Year Parts/Labor Warranty Available
7 Year Compressor Warranty

CABINET CONSTRUCTION

- Stainless steel front and grille, gray painted sides
- Gray painted aluminum interior
- Full electronic control
- LED lighting
- Self-closing doors with 120° stay-open feature, on spring-loaded hinges
- One-piece grille allow easy removal/installation for preventative maintenance
- Nine (9) heavy duty epoxy coated wire shelves standard
- 6" Casters standard with (2) brakes

OPTIONS & ACCESSORIES

- 3 Year parts/labor standard, additional 2 year warranty available
- Stainless steel universal tray slide (AC)
- Additional epoxy shelves
- Shelf clips
- 3" Casters or 6" legs
- 6" Flanged/seismic feet
- Door locks
- Remote option* (see note on back page)

REFRIGERATION SYSTEM

- Uses environmentally friendly, energy efficient R290 refrigerant, and meets all regulatory requirements for CARB, SNAP, DOE & more
- Hot gas condensate evaporator
- Adaptive defrost
- Epoxy coated evaporator coil
- Maintains product temperatures of 0° F and below



 Please verify qualifying units by visiting:
www.energystar.gov/cfs

3779 Champion Blvd., Winston-Salem, NC 27105
1-888-845-9800 Fax: 1-336-245-6453
Beverage-Air.com Sales@bevair.com



BEVERAGE-AIR

VISTA® Bottom Mount Reach-In Freezer Model: FB72HC-5G

MODEL	FB72HC-5G
EXTERNAL DIMENSIONAL DATA	
Width Overall	75"
Depth Overall with Handle	33 3/4"
Height Overall	84 1/4"
Number of Doors	3
Depth with Door Open 90°	55 1/8"
Door Openings (in)	21 5/8" x 52 5/8"
INTERNAL DIMENSIONAL DATA	
NET Capacity (cubic ft.)	68.5
Internal Width Overall (in)	72"
Internal Depth Overall (in)	26"
Internal Height Overall (in)	61 5/8"
Internal Height Useable (in)	53"
Number of Shelves	9
ELECTRICAL DATA	
Full Load Amperes 125/250/60/1	14
REFRIGERATION DATA	
Horsepower	(2) 3/4
Capacity (BTU/Hr)	4624
Heat Rejection (BTU/Hr)	6936
Charge (lbs/grams/ounce)	0.3312 / 150 / 5.3
SHIPPING DATA	
Gross Weight (crated lbs)	748 lbs
Height - Crated	84"
Width - Crated	78"
Depth - Crated	36"

*NOTE: Remote units are field wired and come with 6" legs.
Refrigerant must be specified at time of order.

Model Views

Required Clearance: Rear 3" & Bottom 3"

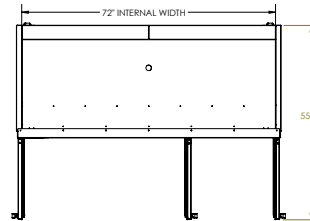

PLAN VIEW

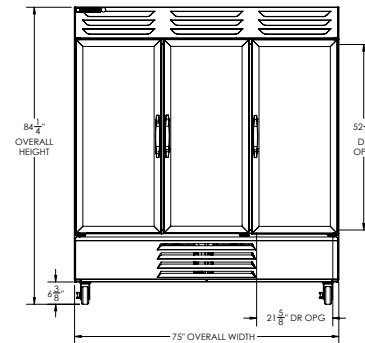

ELEVATION VIEW

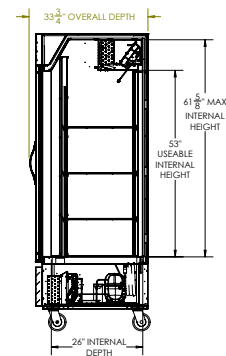

SIDE VIEW

ELECTRICAL CONNECTION



125/250/60/1
NEMA L14-20P

Units pre-wired at factory and include 8' long cord and plug set.



3779 Champion Blvd., Winston-Salem, NC 27105 1-888-845-9800 Fax: 1-336-245-6453 Beverage-Air.com Sales@bevair.com

an Ali Group Company



The Spirit of Excellence